



# Roots pumps

**For all low and medium vacuum applications**

# Roots pumps



<b>Introduction Roots pumps</b> .....	<b>4</b>
Overview / Applications	
<b>Convection-cooled – OktaLine</b> .....	<b>8</b>
Function and description .....	9
Dimensions .....	10
Pumping speed .....	13
Technical data / Order numbers / Accessories .....	14
<b>Gas-circulation-cooled – OktaLine G</b> .....	<b>16</b>
Function and description .....	17
Dimensions .....	18
Pumping speed .....	20
Technical data / Order numbers / Accessories .....	22
<b>Explosion-protected – OktaLine ATEX</b> .....	<b>24</b>
Function and description .....	25
Dimensions .....	26
Pumping speed .....	28
Technical data / Order numbers / Accessories .....	30
<b>Vacuum solutions from a single source</b> .....	<b>32</b>
Market segments and applications .....	32
Product overview .....	36

# Roots pumps



## For all low and medium vacuum applications

The OktaLine series Roots pumps can be perfectly tailored to customer-specific requirements by different pumping speeds and versions. This type of pump needs a backing pump both suited to the application and designed for the gas stream.

The high-precision production technology makes it possible to achieve very high compression values, which in turn allows for maximum pumping speed at very low gas exit temperatures. Pfeiffer Vacuum Roots pumps offer low operating costs at high uptime, since electrical power and (depending on the process) a gaseous purge medium (e.g. air) are all that they require. A high cost water-cooling unit is not required. The magnetic coupled version makes leaks at the shaft feedthrough an issue of the past.

Used in combination with other Roots pumps or appropriate backing pumps, Roots pumps can be adapted perfectly to any application. Pfeiffer Vacuum as the leading supplier of vacuum solutions has more than 50 years of experience in the design of customer-specific solutions.

## Customer benefits

- Large pumping speed range from 145 to 27,400 m<sup>3</sup>/h
- Long life due to robust, compact design
- Short pumpdown time by high compression ratio and overflow valve
- Maintenance free at high operating safety and maximum availability due to the optional magnetic coupling
- Low operating costs because of air cooling and optional magnetic coupling
- A cooling water unit is not required
- Pumps available in stainless steel versions upon request
- Energie efficient, frequency converter suitable standard motors





# Roots pumps

## Overview of series and applications

Analytics	Semiconductor	Coating	Industry	R&D
Electron microscopy				
Leak detection				
Mass spectrometry				
Surface analysis				
Plasma monitoring				
Residual gas analysis				
Lithography				
Physical Vapor Deposition (PVD)				
Chemical Vapor Deposition (CVD)				
Plasma etching				
Implantation – Source				
Implantation – Beamline				
Inspection				
Bonding				
MBE (Molecular Beam Epitaxy)				
Load-locks, transfer chambers, handling systems				
Flat Panel Display (FPD)				
LED / OLED				
Hard disk coating				
Photovoltaics				
Glass coating (PVD)				
CD / DVD / Blu-ray production (PVD)				
Optical coating (PVD)				
Wear protection (PVD, CVD)				
Web coating				
Medical technology				
Industrial leak detection				
Electron beam welding				
Isolation vacuums				
Lamp and tube manufacturing				
Heat treatment				
Vacuum drying				
Vacuum furnaces				
Nuclear research				
Fusion technology				
Plasma research				
Particle accelerators				
Space simulation				
Cryogenic research				
Elementary particle physics				
Nanotechnology				
Biotechnology				

■ = recommended

### Roots pumps

#### Convection-cooled – OktaLine

Okta 250																				
Okta 500																				
Okta 1000																				
Okta 2000																				
Okta 4000																				
Okta 6000																				
Okta 8000																				
Okta 18000																				

#### Gas-circulation-cooled – OktaLine G

Okta 500 G																				
Okta 1500 G																				
Okta 4000 G																				
Okta 8000 G																				

#### Explosion-protected – OktaLine ATEX

Okta 500 ATEX																				
Okta 1000 ATEX																				
Okta 2000 ATEX																				
Okta 4000 ATEX																				

## Overview of series

- Convection-cooled – OktaLine
- Gas-circulation-cooled – OktaLine G
- Explosion-protected – OktaLine ATEX  
(in accordance with Directive 94/9/EC)
- Magnetic coupling as an option of all models

The integrated overflow valve is standard in all convection-cooled pumps. This makes it possible to switch the pump on at atmospheric pressure. The pump is thus automatically protected from thermal overload. The gain in additional pumping speed allows for shorter cycle times in load-lock applications and time-critical processes. Monitoring with fault-prone pressure switches and slow start up with cost-intensive frequency converters is no longer needed.

### Typical applications:

- Glass and foil coating
- Plasma etching
- PVD and CVD
- Vacuum metallurgy
- Space simulation
- Vacuum drying / freeze drying
- Steel degassing / secondary metallurgy
- Electron beam welding

## Advantages of magnetic coupling

All pump models of the OktaLine series can optionally be driven by means of a permanent-magnetic coupling with can. The static seal prevents a bidirectional exchange of process gas and the ambient atmosphere. These pumps are permanently hermetically sealed.

The magnetic coupling implicates further advantages: Maintenance oil changes as they become mandatory for pumps with driveshaft feedthrough are no longer necessary. Downtime and service costs will be reduced.

## Integrated magnet coupling

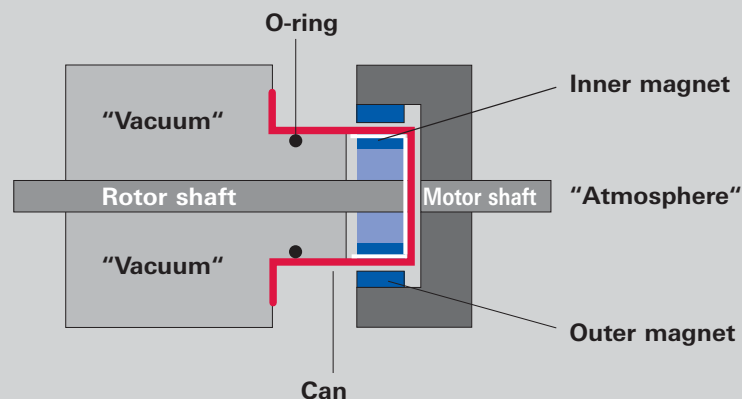

## **Convection-cooled OktaLine Roots pumps for all low and medium vacuum applications**

The pumping speeds of convection-cooled Roots pumps range from 145 to 27,400 m<sup>3</sup>/h. They can easily be combined and used in low and medium vacuum applications. Typical uses include industrial applications, coating, the semiconductor industry and research & development, or in chemical and process technology applications.

The gear box and bearings in our Roots pumps are separated from the gas pumping chamber. The contactless operating principle of the Roots pistons allows for technically dry operations.

A further advantage: due to convection cooling, installation and operating costs are significantly lower than for water-cooled pumps. The OktaLine can therefore be used universally.

The design concept for our proven Roots pumps was expanded to include magnetic couplings. These hermetically sealed pumps in the OktaLine M series mean that critical gases such as helium can be pumped without any problems and operating costs are minimized as the system works without a shaft feedthrough.

## **Customer benefits**

- Complete line of Roots pumps offers optimum flexibility and maximum process suitability
- Broad range of pumping speeds: 145 to 27,400 m<sup>3</sup>/h
- Rugged, compact design
- Fast evacuation due to high compression ratio and overflow valve
- Maintenance free at maximum reliability and highest uptime thanks to magnetic coupling
- Low operating costs thanks to air cooling and magnetic coupling
- No thermal overload because of integral overflow valve
- Long service intervals and simple on-site maintenance
- On-site service worldwide





## Applications

- Metallurgy
- Simulation chambers
- Packaging industry
- Freeze/vacuum-drying
- Thin-film technology
- Electron beam welding
- Load-locks
- Chemistry and process technology
- Industrial leak detection systems
- Steel degassing

# Convection-cooled – OktaLine

## Dimensions

### Okta 250

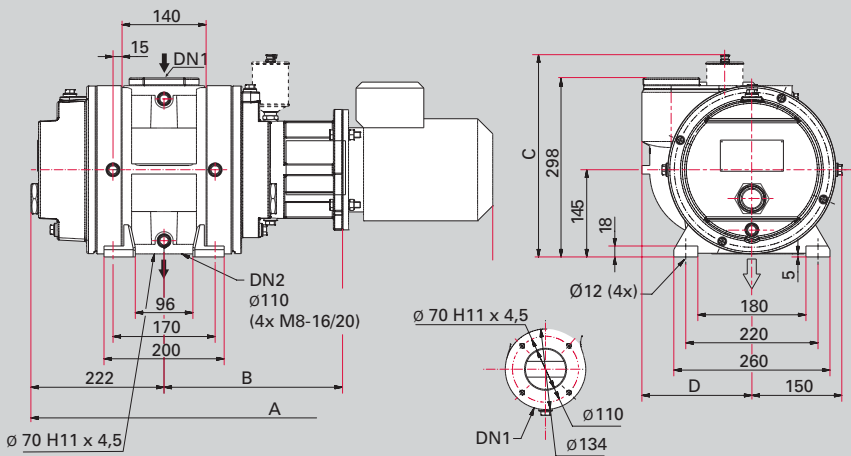

	Okta 250 standard	Okta 250 without motor	Okta 250 M
A	769 mm	-	799 mm
B	297 mm	297 mm	327 mm
C	337 mm	337 mm	298 mm
D	183 mm	183 mm	183 mm

#### Connections

DN 1	DN 63 ISO-F	DN 63 ISO-F	DN 63 ISO-F
DN 2	DN 63 ISO-F	DN 63 ISO-F	DN 63 ISO-F

### Okta 500

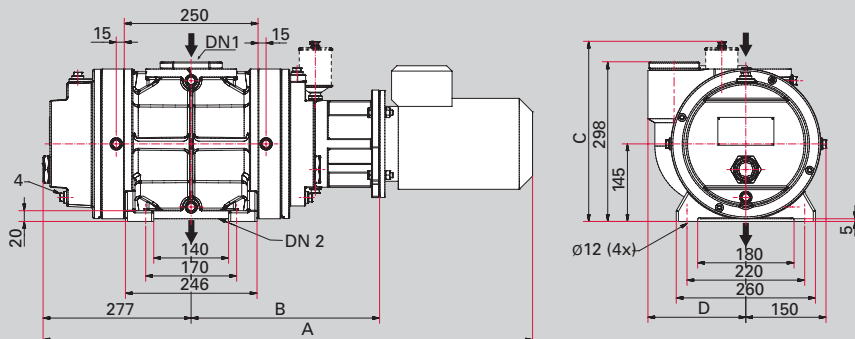

	Okta 500 standard	Okta 500 without motor	Okta 500 M
A	915 mm	-	950 mm
B	352 mm	352 mm	382 mm
C	337 mm	337 mm	298 mm
D	183 mm	183 mm	183 mm

#### Connections

DN 1	DN 100 ISO-F	DN 100 ISO-F	DN 100 ISO-F
DN 2	DN 100 ISO-F	DN 100 ISO-F	DN 100 ISO-F

Dimensions in mm

## Okta 1000

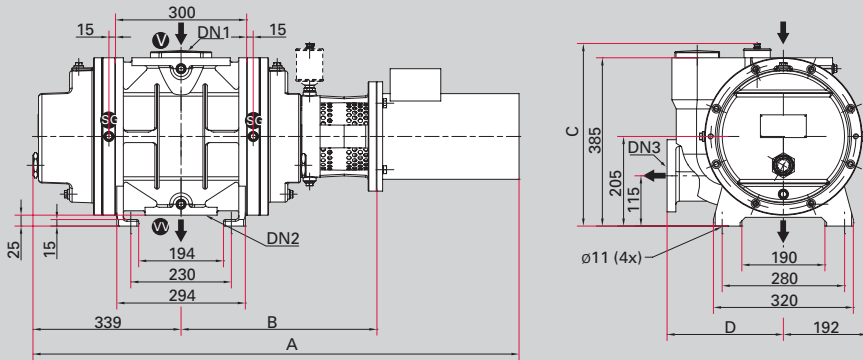

	Okta 1000 standard	Okta 1000 without motor	Okta 1000 M
A	1112 mm	-	1125 mm
B	448 mm	448 mm	461 mm
C	418 mm	418 mm	402 mm
D	266 mm	266 mm	266 mm
<b>Connections</b>			
DN 1	DN 160 ISO-F	DN 160 ISO-F	DN 160 ISO-F
DN 2	DN 100 ISO-F	DN 100 ISO-F	DN 100 ISO-F
DN 3	DN 100 ISO-F	DN 100 ISO-F	DN 100 ISO-F

## Okta 2000

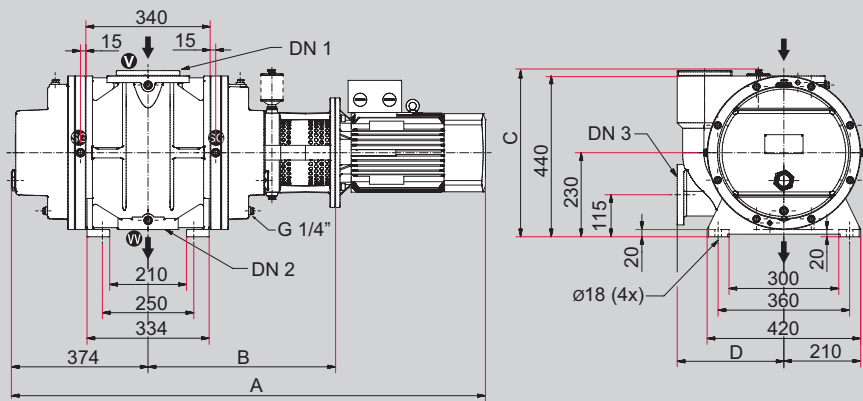

	Okta 2000 standard	Okta 2000 without motor	Okta 2000 M
A	1297 mm	-	1317 mm
B	513 mm	513 mm	532 mm
C	458 mm	458 mm	458 mm
D	292 mm	292 mm	292 mm
<b>Connections</b>			
DN 1	DN 160 ISO-F	DN 160 ISO-F	DN 160 ISO-F
DN 2	DN 100 ISO-F	DN 100 ISO-F	DN 100 ISO-F
DN 3	DN 100 ISO-F	DN 100 ISO-F	DN 100 ISO-F

## Okta 4000

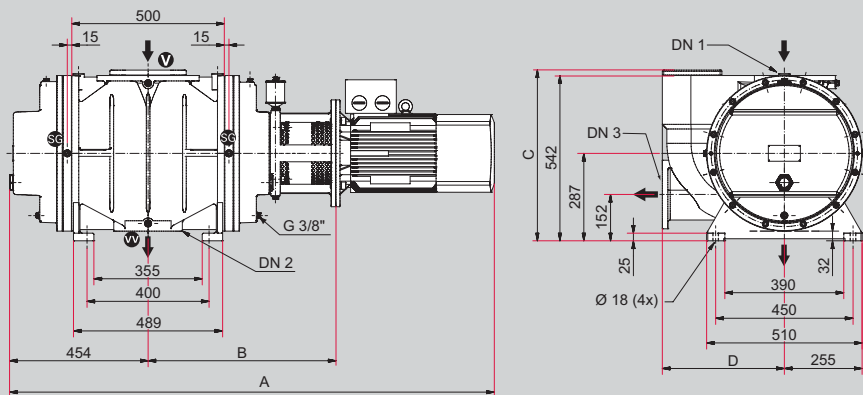

	Okta 4000 standard	Okta 4000 without motor	Okta 4000 M
A	1589 mm	-	1651 mm
B	616 mm	616 mm	678 mm
C	560 mm	560 mm	560 mm
D	400 mm	400 mm	400 mm
<b>Connections</b>			
DN 1	DN 250 ISO-F/ DN 250 PN 16	DN 250 ISO-F/ DN 250 PN 16	DN 250 ISO-F/ DN 250 PN 16
DN 2	DN 160 ISO-F/ DN 150 PN 16	DN 160 ISO-F/ DN 150 PN 16	DN 160 ISO-F/ DN 150 PN 16
DN 3	DN 160 ISO-F/ DN 150 PN 16	DN 160 ISO-F/ DN 150 PN 16	DN 160 ISO-F/ DN 150 PN 16

Dimensions in mm

# Convection-cooled – OktaLine

## Dimensions

### Okta 6000

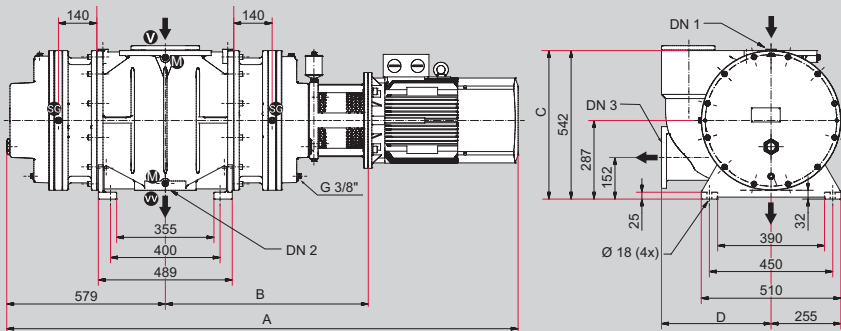

	Okta 6000 standard	Okta 6000 without motor	Okta 6000 M
A	1867 mm	-	1930 mm
B	741 mm	741 mm	803 mm
C	560 mm	560 mm	510 mm
D	400 mm	400 mm	390 mm
<b>Connections</b>			
DN 1	DN 250 ISO-F/ DN 250 PN 16	DN 250 ISO-F/ DN 250 PN 16	DN 250 ISO-F/ DN 250 PN 16
DN 2	DN 160 ISO-F/ DN 150 PN 16	DN 160 ISO-F/ DN 150 PN 16	DN 160 ISO-F/ DN 150 PN 16
DN 3	DN 160 ISO-F/ DN 150 PN 16	DN 160 ISO-F/ DN 150 PN 16	DN 160 ISO-F/ DN 150 PN 16

### Okta 8000

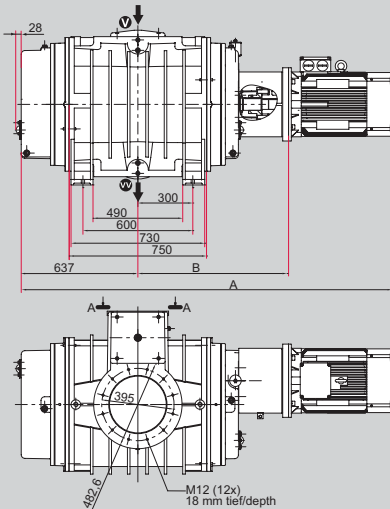

### Okta 18000

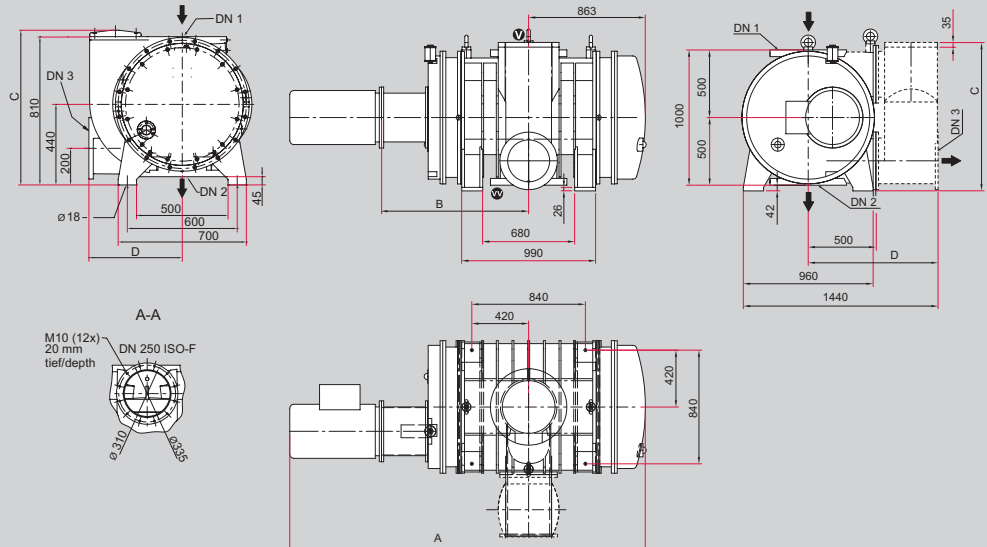

	Okta 8000 standard	Okta 8000 without motor
A	2160 mm	-
B	791 mm	791 mm
C	845 mm	845 mm
D	510 mm	510 mm
<b>Connections</b>		
DN 1	DN 320 ISO-F	DN 320 ISO-F
DN 2	DN 320 ISO-F	DN 320 ISO-F
DN 3	DN 250 ISO-F	DN 250 ISO-F

	Okta 18000 standard	Okta 18000 without motor
A	2789 mm	-
B	1090 mm	1090 mm
C	1099 mm	1099 mm
D	960 mm	960 mm
<b>Connections</b>		
DN 1	DN 400 PN 10	DN 400 PN 10
DN 2	DN 400 PN 10	DN 400 PN 10
DN 3	DN 320 ISO-F	DN 320 ISO-F

Dimensions in mm

# Pumping speed

## Okta 250

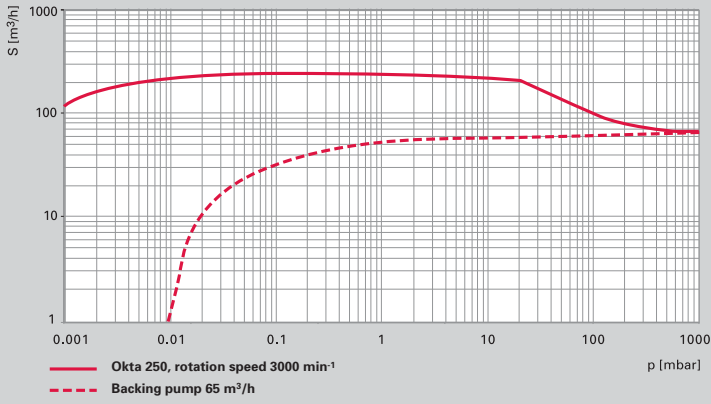

## Okta 500

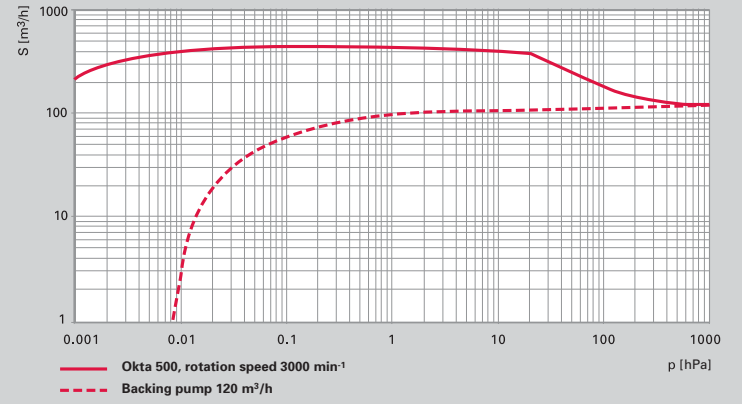

## Okta 1000

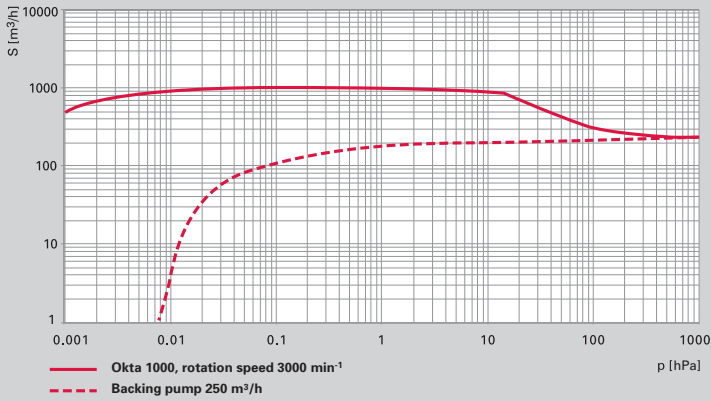

## Okta 2000

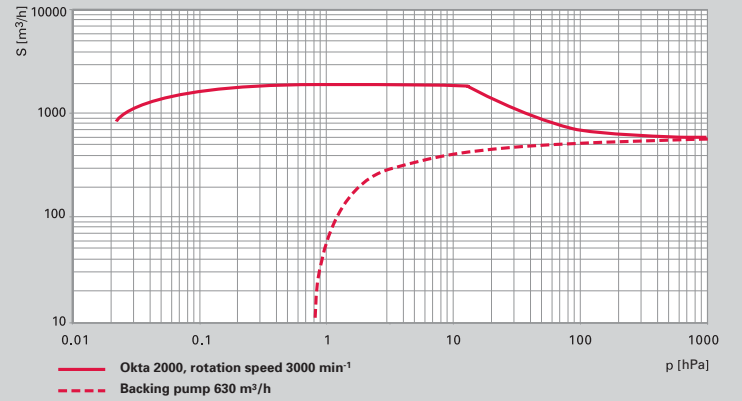

## Okta 4000

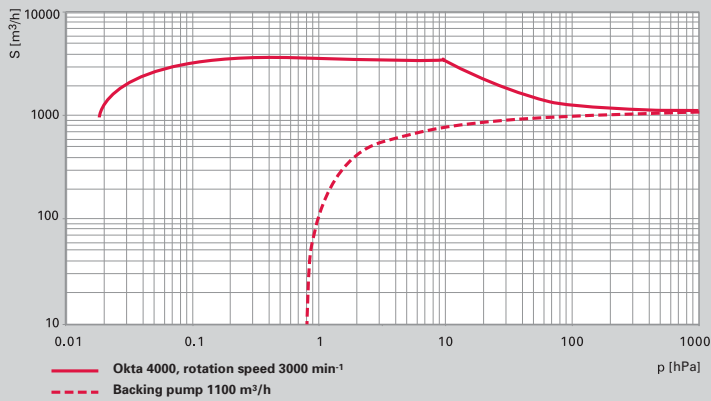

## Okta 6000

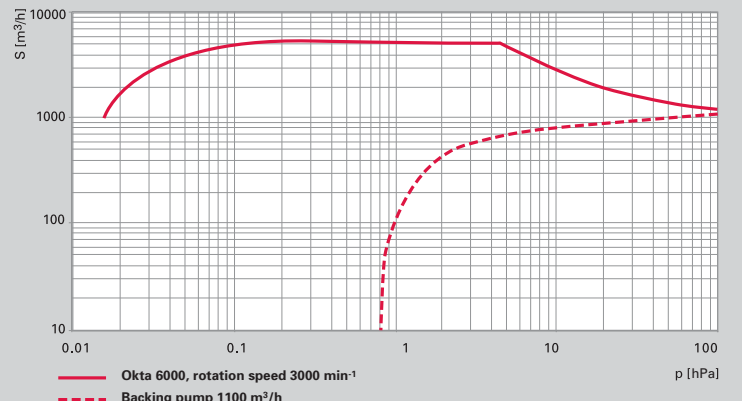

## Okta 8000

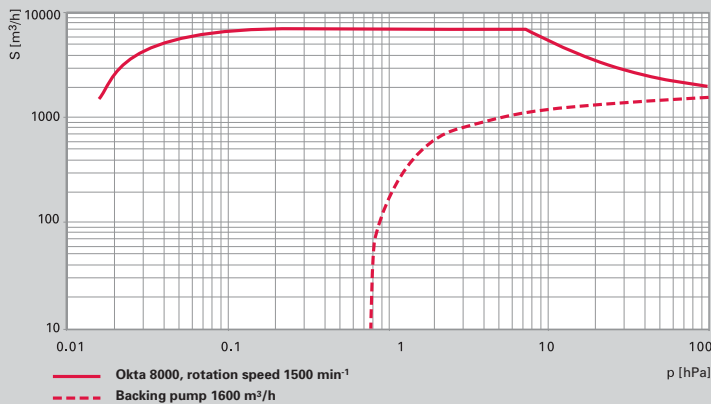

## Okta 18000

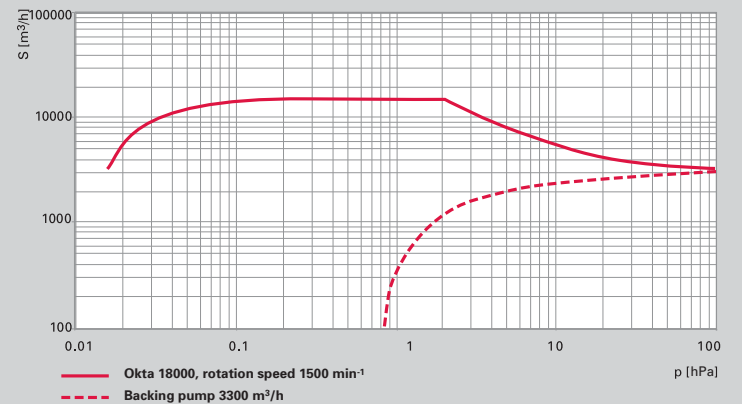

# Convection-cooled – OktaLine

## Technical data

Pump type	Okta 250	Okta 500	Okta 1000
Flange (out)	DN 63 ISO-F	DN 100 ISO-F	DN 100 ISO-F
Flange (in)	DN 63 ISO-F	DN 100 ISO-F	DN 160 ISO-F
Operating fluid <sup>1)</sup>	P3	P3	P3
Operating fluid filling	1.5 l	1.5 l	2.9 l
Differential pressure at the overflow valve <sup>2)</sup>	75 hPa	75 hPa	45 hPa
Rotation speed max.	4500 min <sup>-1</sup>	4500 min <sup>-1</sup>	4500 min <sup>-1</sup>
Rotation speed min.	1500 min <sup>-1</sup>	1500 min <sup>-1</sup>	1500 min <sup>-1</sup>
Emission sound pressure level (EN ISO 2151) at intake pressure 10 hPa	75 dB (A)	75 dB (A)	75 dB (A)
Emission sound pressure level (EN ISO 2151) at intake pressure 1 hPa	70 dB (A)	70 dB (A)	72 dB (A)
Weight: with motor	95 kg	132 kg	240 kg
Weight: without motor	85 kg	115 kg	215 kg
Weight: with magnet coupling	122 kg	145 kg	265 kg
Cooling method, standard	Luft	Air	Air
Leak rate: standard	1 · 10 <sup>-3</sup> Pa m <sup>3</sup> /s	1 · 10 <sup>-3</sup> Pa m <sup>3</sup> /s	1 · 10 <sup>-3</sup> Pa m <sup>3</sup> /s
Leak rate: with magnet coupling	1 · 10 <sup>-6</sup> Pa m <sup>3</sup> /s	1 · 10 <sup>-6</sup> Pa m <sup>3</sup> /s	1 · 10 <sup>-6</sup> Pa m <sup>3</sup> /s
Motor protection	3TF	3TF	3TF
Nominal rotation speed at 50 Hz	3000 min <sup>-1</sup>	3000 min <sup>-1</sup>	3000 min <sup>-1</sup>
Nominal rotation speed at 60 Hz	3600 min <sup>-1</sup>	3600 min <sup>-1</sup>	3600 min <sup>-1</sup>
Rated power 50 Hz	0.75 kW	1.5 kW	3.0 kW
Rated power 60 Hz	0.90 kW	1.8 kW	3.5 kW
Nominal pumping speed	145–440 m <sup>3</sup> /h	280–840 m <sup>3</sup> /h	590–1775 m <sup>3</sup> /h
Nominal pumping speed at 50 Hz	290 m <sup>3</sup> /h	560 m <sup>3</sup> /h	1180 m <sup>3</sup> /h
Nominal pumping speed at 60 Hz	350 m <sup>3</sup> /h	670 m <sup>3</sup> /h	1420 m <sup>3</sup> /h
Mains requirement: voltage 50 Hz	230/400 V	230/400 V	230/400 V
Mains requirement: voltage 60 Hz	265/460 V	265/460 V	265/460 V
Protection category	IP 55	IP 55	IP 55
Ambient temperature	5-40 °C	5-40 °C	5-40 °C

## Order number

Okta (Standard)	PP W21 000	PP W31 000	PP W41 000
Okta without motor	PP W21 001	PP W31 001	PP W41 001
Okta M	PP W22 000	PP W32 000	PP W42 000

## Accessories

Splinter shield	PK 300 010 -X	PP 030 149 AX	PP 031 114 -X
-----------------	---------------	---------------	---------------

<sup>1)</sup> Additional equipment and motor voltages available upon request.

<sup>2)</sup> The differential pressure at the overflow valve is based on a nominal speed of 60 Hz; for higher speeds or pressure differentials please contact the Pfeiffer Vacuum sales department.

<b>Okta 2000</b>	<b>Okta 4000</b>	<b>Okta 6000</b>	<b>Okta 8000</b>	<b>Okta 18000</b>
DN 100 ISO-F	DN 160 ISO-F/ DN 150 PN 16	DN 160 ISO-F/ DN 150 PN 16	DN 320 ISO-F	DN 400 PN 10
DN 160 ISO-F	DN 250 ISO-F/ DN 250 PN 16	DN 250 ISO-F/ DN 250 PN 16	DN 320 ISO-F	DN 400 PN 10
P3	P3	P3	P3	P3
5 l	6.8 l	6.8 l	21 l	68 l
35 hPa	25 hPa	20 hPa	23 hPa	7 hPa
4500 min <sup>-1</sup>	4500 min <sup>-1</sup>	4500 min <sup>-1</sup>	2250 min <sup>-1</sup>	2250 min <sup>-1</sup>
1500 min <sup>-1</sup>	1500 min <sup>-1</sup>	1500 min <sup>-1</sup>	1200 min <sup>-1</sup>	1200 min <sup>-1</sup>
75 dB (A)	79 dB (A)	79 dB (A)	78 dB (A)	79 dB (A)
72 dB (A)	74 dB (A)	74 dB (A)	74 dB (A)	75 dB (A)
340 kg	640 kg	840 kg	1660 kg	3100 kg
290 kg	520 kg	715 kg	1480 kg	2800 kg
360 kg	655 kg	875 kg	–	–
Air	Air	Air	Air	Air
1 · 10 <sup>-3</sup> Pa m <sup>3</sup> /s	1 · 10 <sup>-3</sup> Pa m <sup>3</sup> /s	1 · 10 <sup>-3</sup> Pa m <sup>3</sup> /s	1 · 10 <sup>-3</sup> Pa m <sup>3</sup> /s	1 · 10 <sup>-3</sup> Pa m <sup>3</sup> /s
1 · 10 <sup>-6</sup> Pa m <sup>3</sup> /s	1 · 10 <sup>-6</sup> Pa m <sup>3</sup> /s	1 · 10 <sup>-6</sup> Pa m <sup>3</sup> /s	–	–
3TF	3TF	3TF	3TF	3TF
3000 min <sup>-1</sup>	3000 min <sup>-1</sup>	3000 min <sup>-1</sup>	1500 min <sup>-1</sup>	1500 min <sup>-1</sup>
3600 min <sup>-1</sup>	3600 min <sup>-1</sup>	3600 min <sup>-1</sup>	1800 min <sup>-1</sup>	1800 min <sup>-1</sup>
5.5 kW	11.0 kW	15.0 kW	22 kW	45 kW
6.3 kW	13.2 kW	18.5 kW	25 kW	52 kW
1075-3230 m <sup>3</sup> /h	2160-6490 m <sup>3</sup> /h	3240-9730 m <sup>3</sup> /h	3350-12550 m <sup>3</sup> /h	7310-27400 m <sup>3</sup> /h
2155 m <sup>3</sup> /h	4325 m <sup>3</sup> /h	6485 m <sup>3</sup> /h	8370 m <sup>3</sup> /h	18270 m <sup>3</sup> /h
2585 m <sup>3</sup> /h	5190 m <sup>3</sup> /h	7785 m <sup>3</sup> /h	10040 m <sup>3</sup> /h	21925 m <sup>3</sup> /h
230/400 V	400/690 V	400/690 V	400/690 V	400/690 V
265/460 V	460 V	460 V	460 V	460 V
IP 55	IP 55	IP 55	IP 55	IP 55
5-40 °C	5-40 °C	5-40 °C	5-40 °C	5-40 °C
<b>PP W61 000</b>	<b>PP W71 000</b>	<b>PP W76 000</b>	<b>PP W80 000</b>	<b>PP W90 000</b>
<b>PP W61 001</b>	<b>PP W71 001</b>	<b>PP W76 001</b>	<b>PP W80 001</b>	<b>PP W90 001</b>
<b>PP W62 000</b>	<b>PP W72 000</b>	<b>PP W77 000</b>		
<b>PP 031 114 -X</b>	<b>PP 031 136 -X</b>	<b>PP 031 136 -X</b>	<b>PP 030 152 -X</b>	<b>PP 030 336 -T</b>

## High differential pressures with lower power consumption

High pressure ranges and maximum differential pressures, in continuous operation up to 870 hPa, are ideal operating conditions for gas-circulation-cooled Roots pumps in the OktaLine G series.

At various power ratings from 5.5 kW up to a nominal rating of 200 kW, a pumping speed of 210 to 12,000 m<sup>3</sup>/h can be achieved. Gas-circulation-cooled Roots pumps can be operated without backing pumps.

Thanks to the frequency converter, energy use can be significantly reduced. Pumping speeds can be precisely adjusted. Gas-circulation-cooled Roots pumps are characterized by maximum reproducibility in process technologies and significantly lower operating costs compared to vacuum process pumps, such as injectors or liquid ring pumps.

Used as stand-alone pumps, they can be used in the pressure range from 130 to 1,013 hPa. Connecting two of these pumps in series enables the ultimate pressure to be reduced to 20 to 30 hPa. In combination with further Roots pumps the possible ultimate pressure can be reduced to the medium vacuum range. The motors and gas coolers needed for operation are both designed to meet process-specific requirements. In combination with Roots pumps it is possible in many cases to dispense with a pumping stage by using the OktaLine G, which saves money and significantly increases operating reliability. Other specific parts such as couplings, temperature sensors, spray equipment and base frames are available as optional components.

## Customer benefits

- Ample pumping speed range from 210 to 12,000 m<sup>3</sup>/h
- High pressure differences
- Flexibility and process adaptation, due to the motor power and frequency converter design.
- Thermal process gas line with OktaLine G and gas coolers
- Maintenance free, maximum reliability and highest uptime thanks to magnetic coupling (optional)





## Applications

- Electron beam welding
- Vacuum furnaces
- Plasma research
- Particle accelerators
- Space simulation
- Chemical and process technology

# Gas-circulation-cooled – OktaLine G

## Dimensions

### Okta 500 G

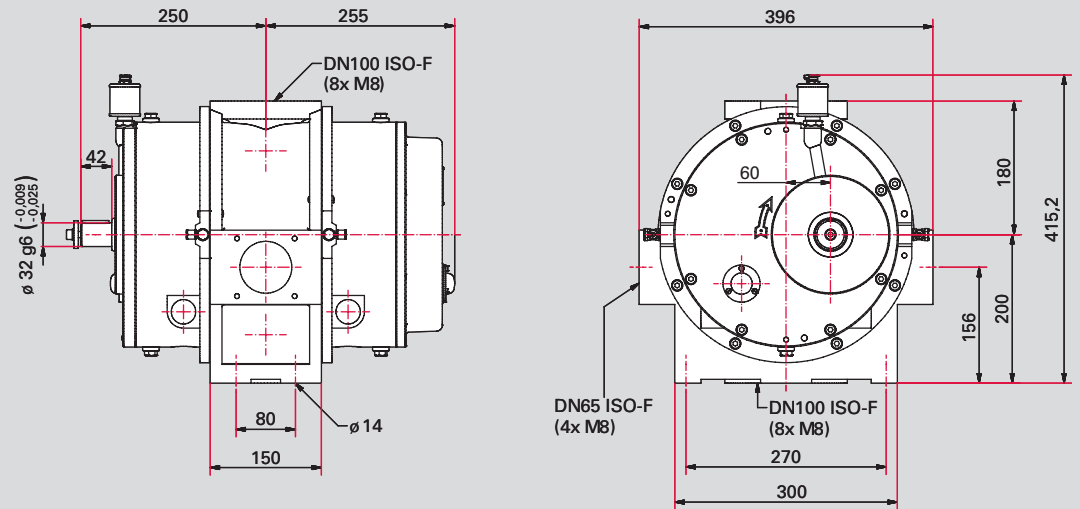

### Okta 1500 G

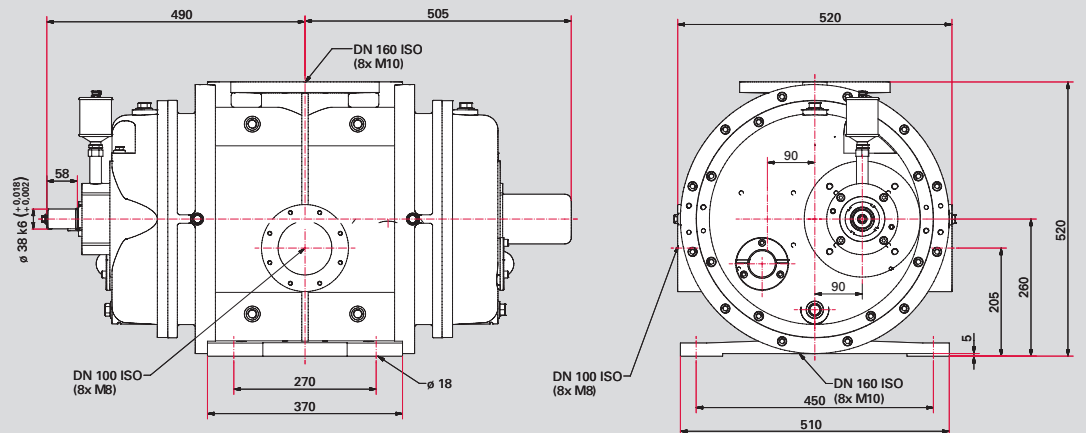

Dimensions in mm

**Okta 4000 G**

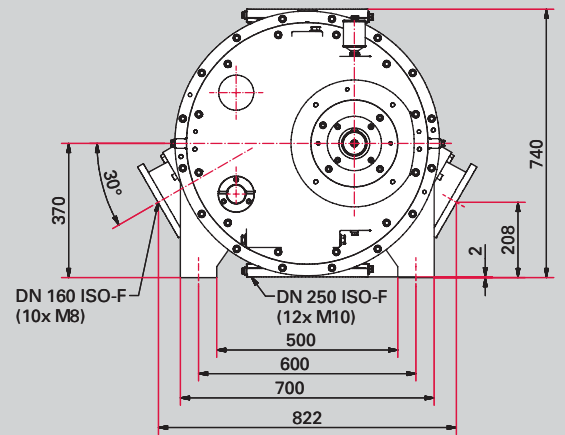
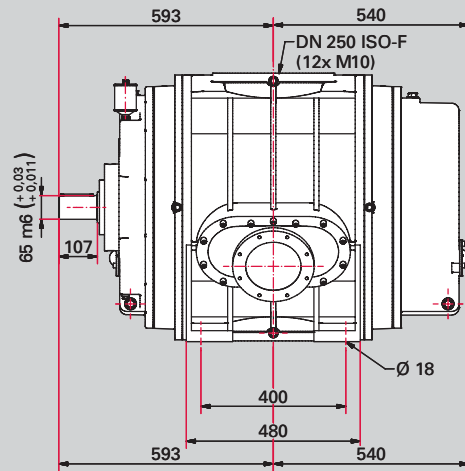

**Okta 8000 G**

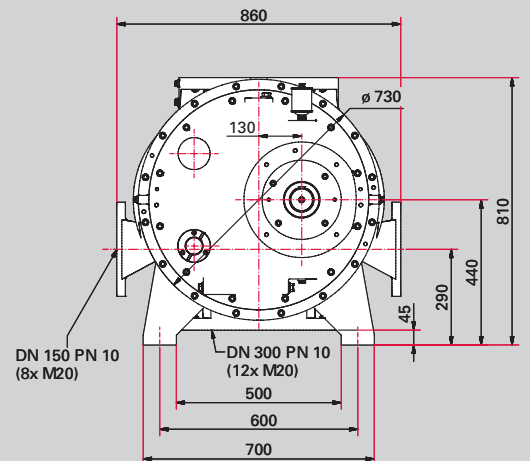
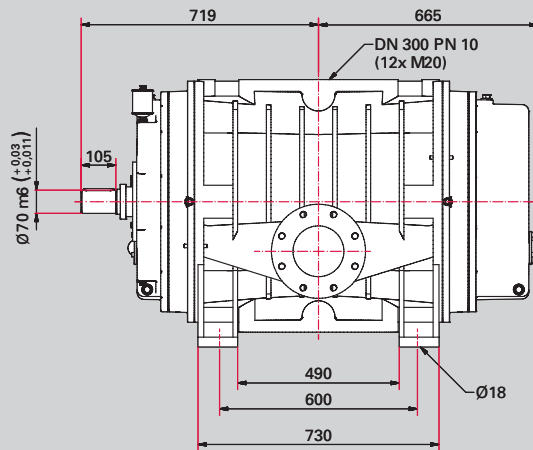

Dimensions in mm

# Gas-circulation-cooled – OktaLine G

## Pumping speed

### Okta 500 G

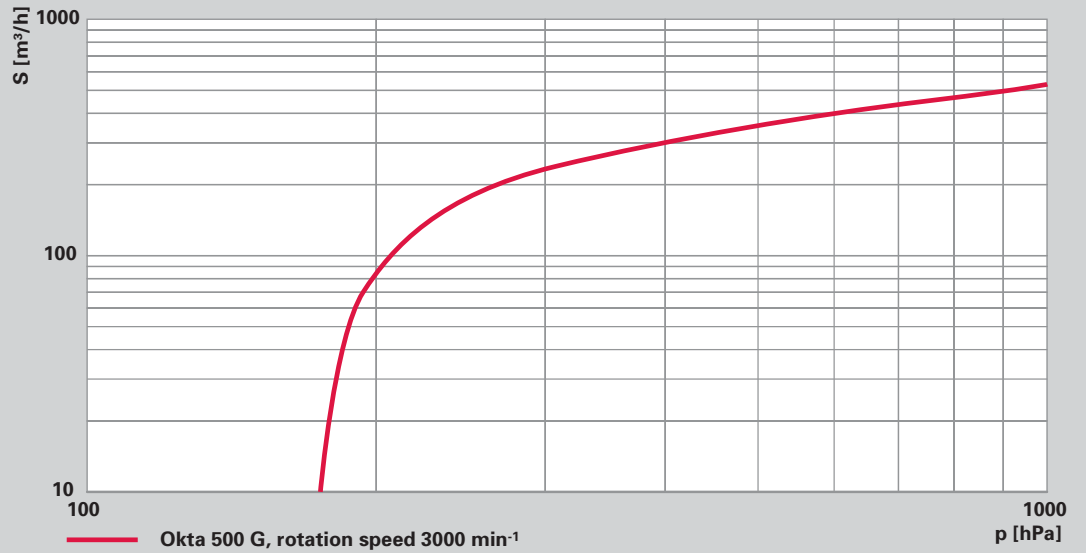

### Okta 1500 G

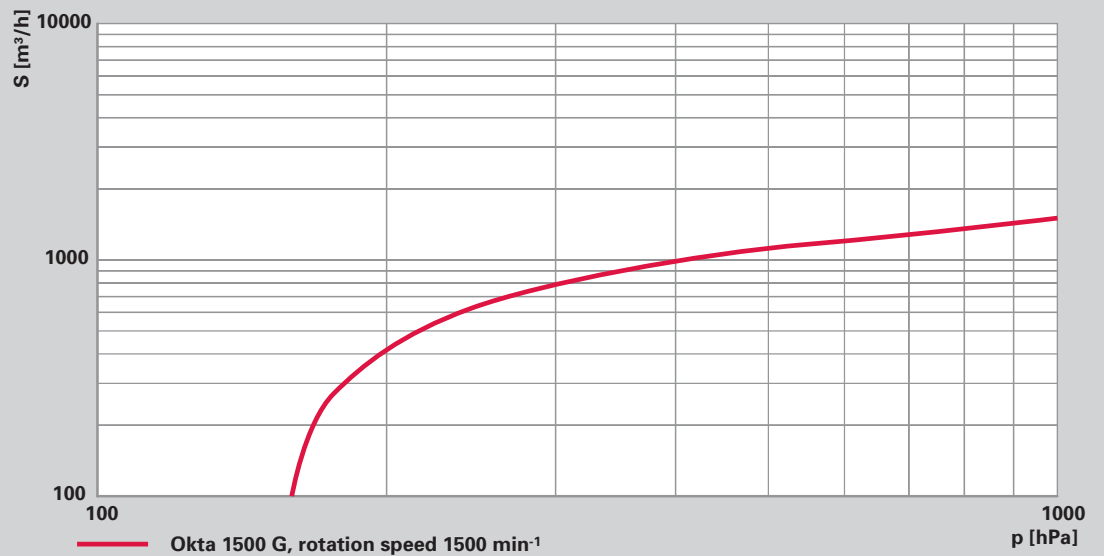

### Okta 4000 G

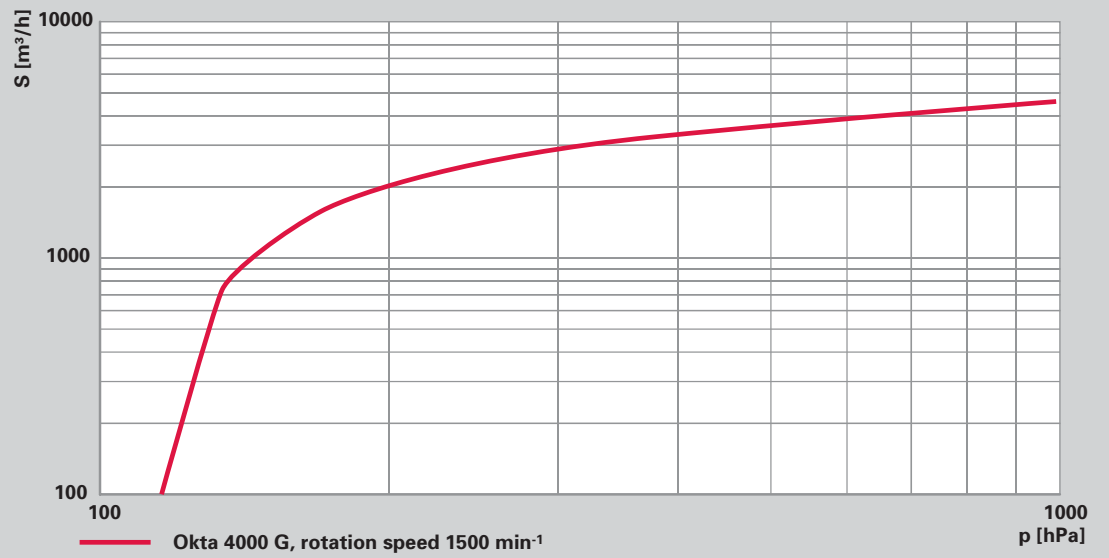

### Okta 8000 G

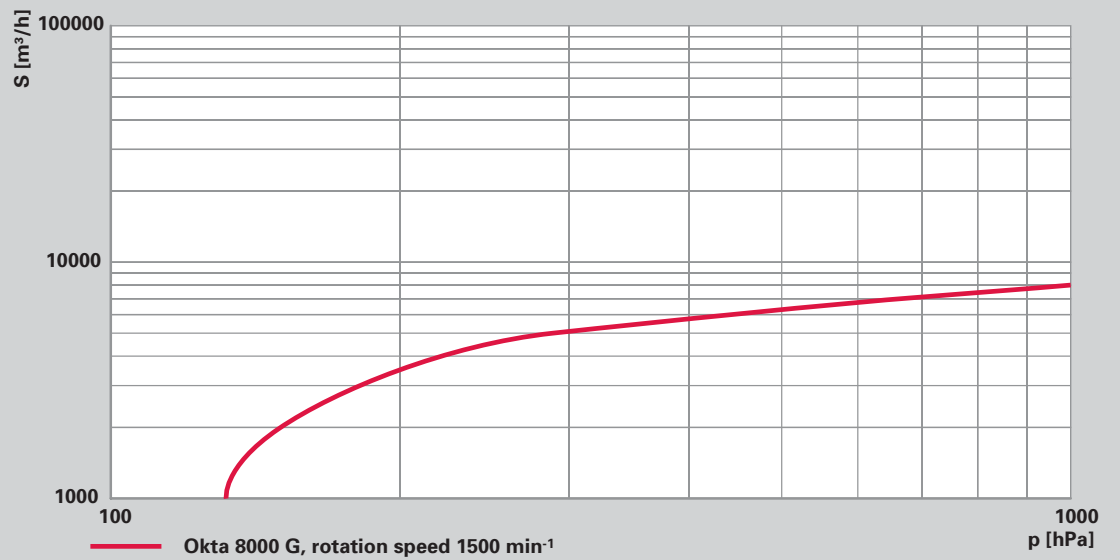

# Gas-circulation-cooled – OktaLine G

## Technical data

Pump type	Okta 500 G	Okta 1500 G
Flange (out)	DN 100 ISO-F	DN 160 ISO-F
Flange (in)	DN 100 ISO-F	DN 160 ISO-F
Operating fluid <sup>1)</sup>	P3	P3
Operating fluid filling	3 l	7 l
Rotation speed	from 1200 to 3600 min <sup>-1</sup>	from 750 to 3600 min <sup>-1</sup>
Rotation speed max.	3600 min <sup>-1</sup>	3600 min <sup>-1</sup>
Rotation speed min.	1200 min <sup>-1</sup>	750 min <sup>-1</sup>
Ultimate pressure without gas ballast	130 hPa	130 hPa
Weight: without motor	125 kg	460 kg
Cooling method, standard	Gas-cooled	Gas-cooled
Cooling gas connection	DN 63 ISO-F	DN 100 ISO-F
Leak rate	1 · 10 <sup>-3</sup> Pa m <sup>3</sup> /s	1 · 10 <sup>-3</sup> Pa m <sup>3</sup> /s
Motor rating	max. 18.5 kW	max. 2 x 30 kW
Nominal rotation speed at 50 Hz	3000 min <sup>-1</sup>	1500 min <sup>-1</sup>
Nominal rotation speed at 60 Hz	3600 min <sup>-1</sup>	1800 min <sup>-1</sup>
Nominal pumping speed	210-630 m <sup>3</sup> /h	750-3600 m <sup>3</sup> /h
Nominal pumping speed at 50 Hz	520 m <sup>3</sup> /h	1500 m <sup>3</sup> /h
Nominal pumping speed at 60 Hz	630 m <sup>3</sup> /h	1800 m <sup>3</sup> /h
Noise level with connected exhaust line	75-105 dB (A)	75-105 dB (A)
Protection category	IP 55	IP 55
Sealing gas	Yes	Yes
Ambient temperature	5-40 °C	5-40 °C

Order number	Okta 500 G	Okta 1500 G
Okta G	PP G30 001	PP G50 001

Accessories	Okta 500 G	Okta 1500 G
Splinter shield für Okta G	PP 030 149 AX	PP 031 114 -X

<sup>1)</sup> Additional equipment and motor voltages available upon request.

<b>Okta 4000 G</b>	<b>Okta 8000 G</b>
DN 250 ISO-F	DN 300 PN 10
DN 250 ISO-F	DN 300 PN 10
P3	P3
21 l	21 l
from 750 to 2250 min <sup>-1</sup>	from 750 to 2250 min <sup>-1</sup>
2250 min <sup>-1</sup>	2250 min <sup>-1</sup>
750 min <sup>-1</sup>	750 min <sup>-1</sup>
130 hPa	130 hPa
1150 kg	1500 kg
Gas-cooled	Gas-cooled
DN 160 ISO-F	DN 150 PN 10
1 · 10 <sup>-3</sup> Pa m <sup>3</sup> /s	1 · 10 <sup>-3</sup> Pa m <sup>3</sup> /s
max. 132 kW	max. 200 kW
1500 min <sup>-1</sup>	1500 min <sup>-1</sup>
1800 min <sup>-1</sup>	1800 min <sup>-1</sup>
2300-6900 m <sup>3</sup> /h	4000-12000 m <sup>3</sup> /h
4600 m <sup>3</sup> /h	8000 m <sup>3</sup> /h
5500 m <sup>3</sup> /h	9600 m <sup>3</sup> /h
75-105 dB (A)	75-105 dB (A)
IP 55	IP 55
Yes	Yes
5-40 °C	5-40 °C

<b>PP G70 001</b>	<b>PP G80 001</b>
-------------------	-------------------

<b>PP 031 136 -X</b>	<b>PP 070 315 -U</b>
----------------------	----------------------

## **Magnetic coupled Roots pumps with ATEX certification for low and medium vacuum application.**

For processes that take place in explosive environments or for evacuating explosive gases we have developed ATEX certified pumps in accordance with directive 94/9/EC (ATEX 95), which meet the high requirements for explosion protection.

Our Roots pumps offer pumping speeds ranging from 280 to 5,190 m<sup>3</sup>/h. Depending on the application, you can choose between equipment category 2G or 3G. All pumps are suitable for temperature class T3.

The gear box and bearing area in our Roots pumps are separated from the gas pumping chamber. Because the rotors operate contactfree, dry operation is assured.

A further advantage: Due to convection cooling, operating costs are significantly lower than with water cooling. The pumps can be utilized universally. The design principle of our proven Roots pumps has also been expanded to include magnetic couplings. Thanks to these hermetically sealed pumps we achieve very low leak rates.

For the operation of the pumps, the terms of the operating instructions apply. We are pleased to provide you with the right solution for your application!

## **Customer benefits**

- Explosion safety due to reliable construction and temperature monitoring – installation without additional flame arrester possible
- Pumps are hermetically sealed (leakrate < 10<sup>-6</sup> Pa m<sup>3</sup>/s) – risk of zone entrainment is minimized
- Pump can be operated without bypass (ATEX protection in case of passive rotation)
- Easiest on-site service even for the motor (can be changed on site thanks to standard ATEX IEC-motors)
- Flexible application due to variable differential pressure and rotational speed\* – pump can start against atmospheric pressure
- Pressure surge resistance according to EN 1333, PN level 16

\*when using a frequency converter





## Applications

- Heat treatment
- Vacuum drying
- Vacuum furnaces
- Biotechnology
- Chemical and process technology

# Explosion-protected – OktaLine ATEX

## Dimensions

### Okta 500 ATEX

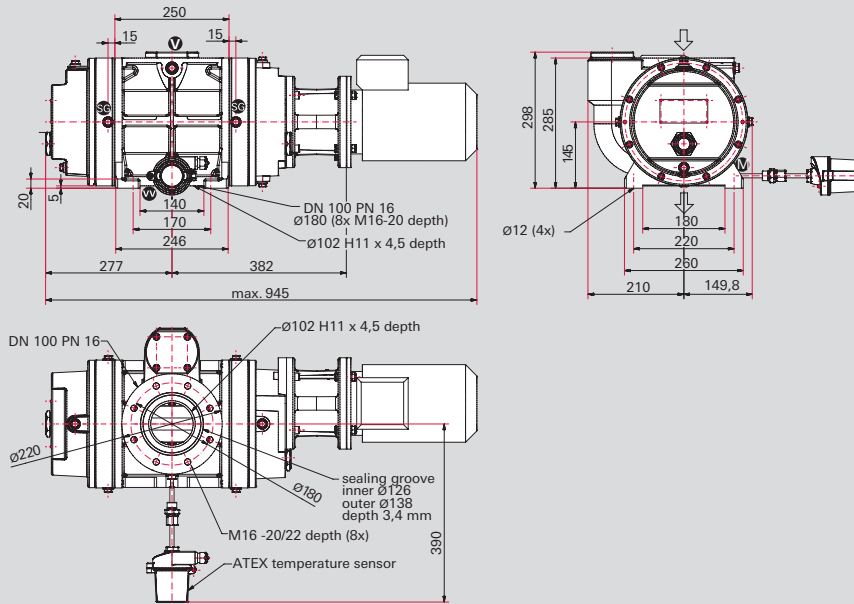

### Okta 1000 ATEX

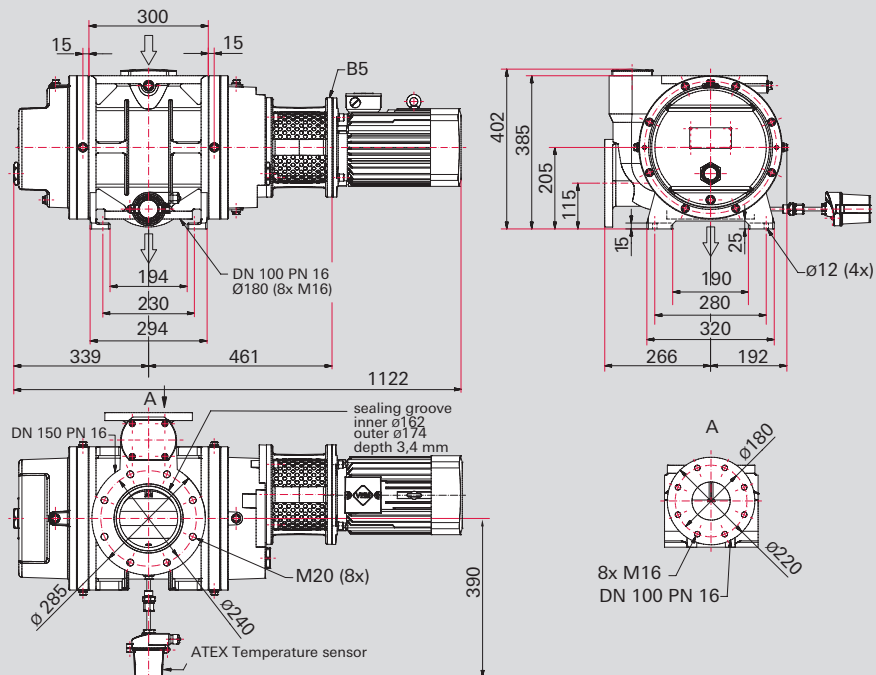

Dimensions in mm

## Okta 2000 ATEX

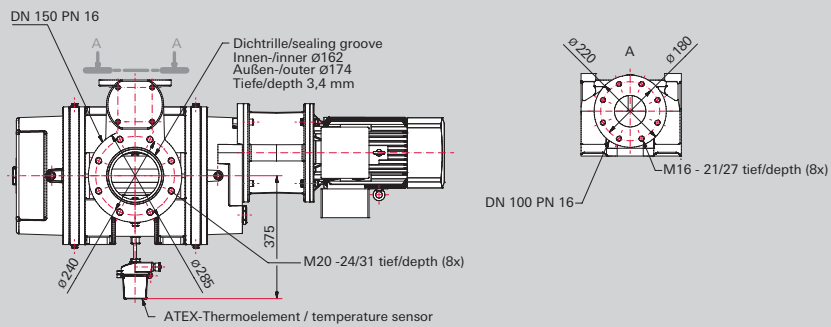
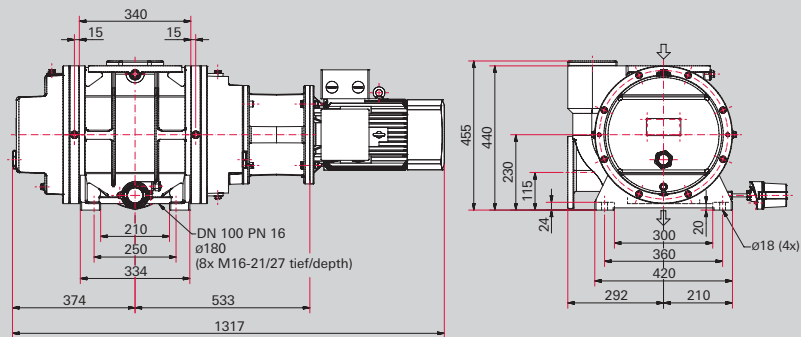

## Okta 4000 ATEX

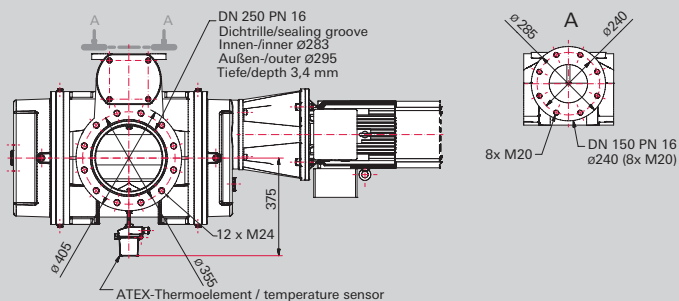
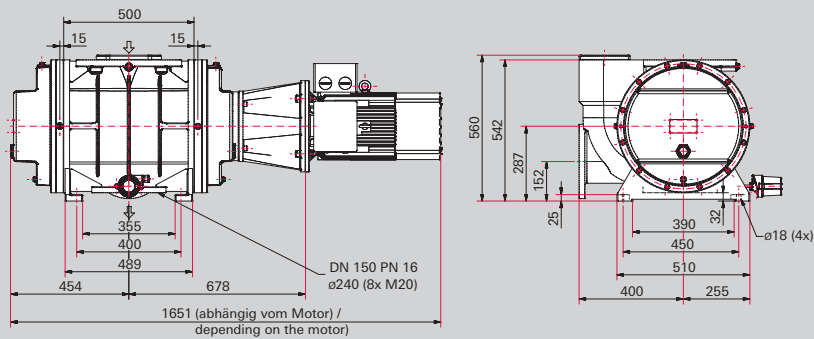

Dimensions in mm

# Explosion-protected – OktaLine ATEX

## Pumping speed

### Okta 500 ATEX

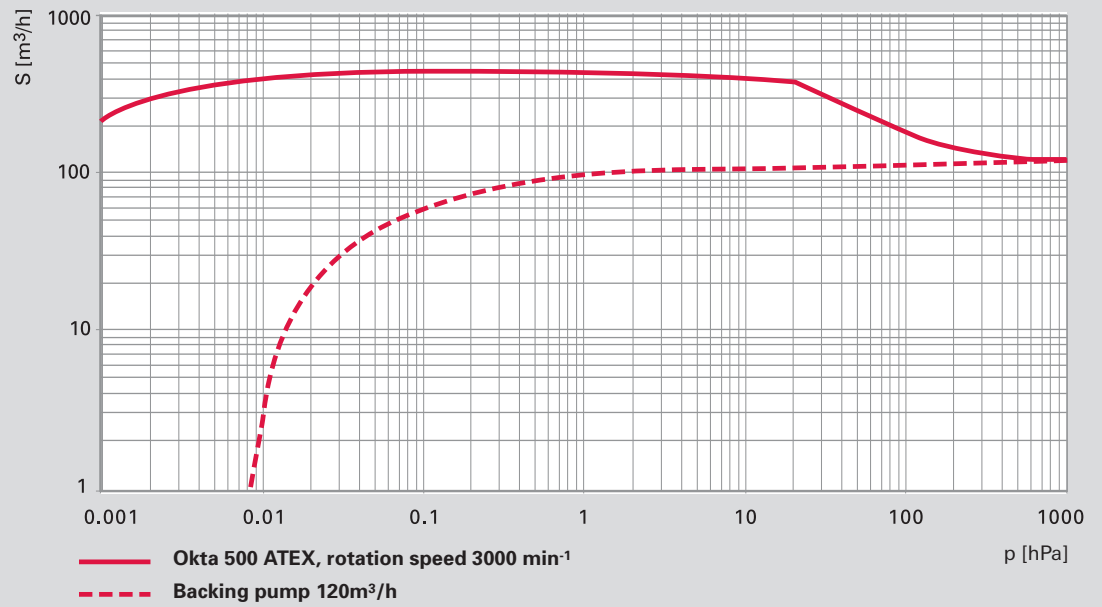

### Okta 1000 ATEX

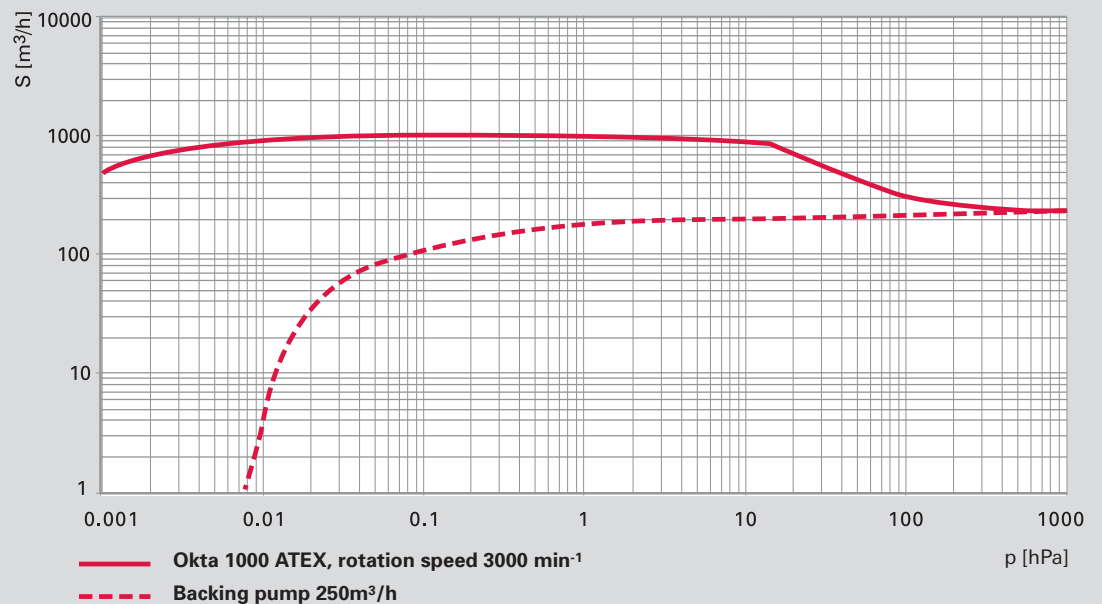

### Okta 2000 ATEX

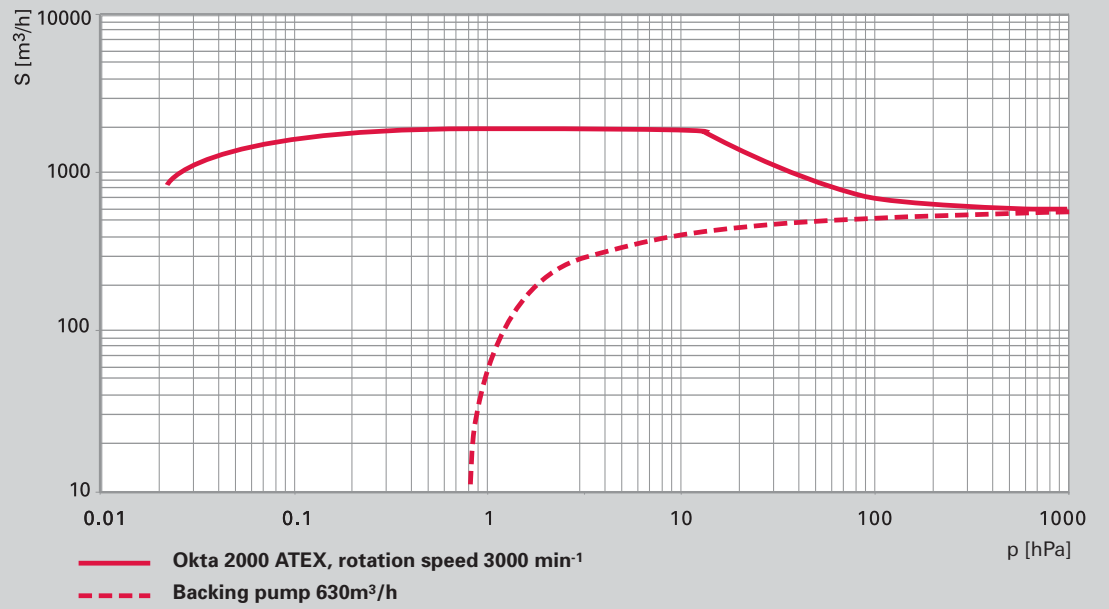

### Okta 4000 ATEX

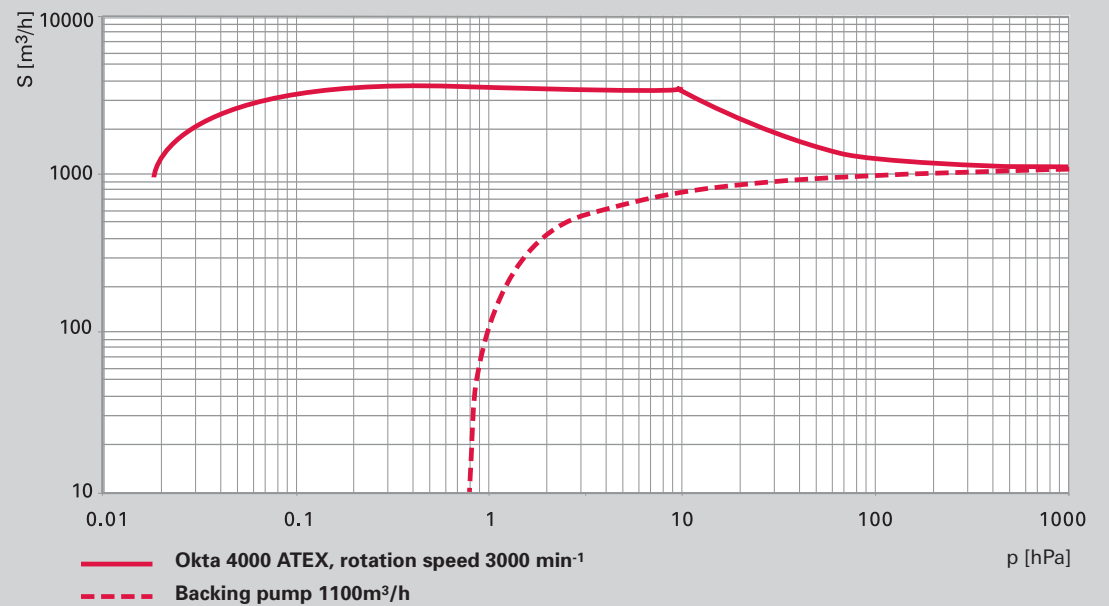

# Explosion-protected – OktaLine ATEX

## Technical data

Pump type	Okta 500 ATEX	Okta 1000 ATEX
Flange (out)	DN 100 PN 16	DN 100 PN 16
Flange (in)	DN 100 PN 16	DN 150 PN 16
Version	ATEX with motor and magnetic coupling, blocked overflow-valve	ATEX with motor and magnetic coupling, blocked overflow-valve
Equipment category	2G <sup>2)</sup> or 3G <sup>3)</sup>	2G <sup>2)</sup> or 3G <sup>3)</sup>
Operating fluid <sup>1)</sup>	P3	P3
Operating fluid filling	1.5 l	2.9 l
Rotation speed	from 1500 to 3600 min <sup>-1</sup>	from 1500 to 3600 min <sup>-1</sup>
Rotation speed max.	3600 min <sup>-1</sup>	3600 min <sup>-1</sup>
Rotation speed min.	1500 min <sup>-1</sup>	1500 min <sup>-1</sup>
Emission sound pressure level (EN ISO 2151) at intake pressure 10 hPa	75 dB (A)	75 dB (A)
Emission sound pressure level (EN ISO 2151) at intake pressure 1 hPa	70 dB (A)	72 dB (A)
Weight: with motor	154 kg	255 kg
Cooling method, standard	Air	Air
Leak rate	1 · 10 <sup>-6</sup> Pa m <sup>3</sup> /s	1 · 10 <sup>-6</sup> Pa m <sup>3</sup> /s
Motor protection	3TF	3TF
Nominal rotation speed at 50 Hz	3000 min <sup>-1</sup>	3000 min <sup>-1</sup>
Nominal rotation speed at 60 Hz	3600 min <sup>-1</sup>	3600 min <sup>-1</sup>
Rated power 50 Hz	1.5 kW	3.0 kW
Rated power 60 Hz	1.8 kW	3.5 kW
Nominal pumping speed	280-670 m <sup>3</sup> /h	590-1420 m <sup>3</sup> /h
Nominal pumping speed at 50 Hz	560 m <sup>3</sup> /h	1180 m <sup>3</sup> /h
Nominal pumping speed at 60 Hz	670 m <sup>3</sup> /h	1420 m <sup>3</sup> /h
Mains requirement: voltage 50 Hz	230/400 V	230/400 V
Mains requirement: voltage 60 Hz	265/460 V	265/460 V
Protection category	IP 55	IP 55
Ambient temperature	5-40 °C	5-40 °C
Order number		
Okta ATEX (3G <sup>3)</sup> )	PP W33 300	PP W43 300
Okta ATEX (2G <sup>2)</sup> )	PP W33 400	PP W43 400

<sup>1)</sup> Additional equipment and motor voltages available upon request.

<sup>2)</sup> According to ATEX directive 94/9/EC: II 2G IIB T3 X + 5 °C ≤ Ta ≤ +40 °C

<sup>3)</sup> According to ATEX directive 94/9/EC: II 3G IIB T3 X + 5 °C ≤ Ta ≤ +40 °C

<b>Okta 2000 ATEX</b>	<b>Okta 4000 ATEX</b>
DN 100 PN 16	DN 150 PN 16
DN 150 PN 16	DN 250 PN 16
ATEX with motor and magnetic coupling, blocked overflow-valve	ATEX with motor and magnetic coupling, blocked overflow-valve
2G <sup>2)</sup> or 3G <sup>3)</sup>	2G <sup>2)</sup> or 3G <sup>3)</sup>
P3	P3
5 l	7 l
from 1500 to 3600 min <sup>-1</sup>	from 1500 to 3600 min <sup>-1</sup>
3600 min <sup>-1</sup>	3600 min <sup>-1</sup>
1500 min <sup>-1</sup>	1500 min <sup>-1</sup>
75 dB (A)	79 dB (A)
72 dB (A)	74 dB (A)
390 kg	700 kg
Air	Air
1 · 10 <sup>-6</sup> Pa m <sup>3</sup> /s	1 · 10 <sup>-6</sup> Pa m <sup>3</sup> /s
3TF	3TF
3000 min <sup>-1</sup>	3000 min <sup>-1</sup>
3600 min <sup>-1</sup>	3600 min <sup>-1</sup>
5.5 kW	11 kW
6.3 kW	13 kW
1080-2585 m <sup>3</sup> /h	2160-5190 m <sup>3</sup> /h
2155 m <sup>3</sup> /h	4325 m <sup>3</sup> /h
2585 m <sup>3</sup> /h	5190 m <sup>3</sup> /h
230/400 V	230/400 V
265/460 V	265/460 V
IP 55	IP 55
5-40 °C	5-40 °C
<b>PP W63 300</b>	<b>PP W73 300</b>
<b>PP W63 400</b>	<b>PP W73 400</b>

# Vacuum solutions from a single source

## Market segments and applications

### The Vacuum solution

Providing solutions means understanding the customer. One vacuum is not just like another vacuum, the key lies in the specific requirements. Which process should be used with which materials to produce the right results? Under which environmental conditions? Our customers demand sophisticated and intelligent results – and rightly so. Their vacuums have to deliver stability and low-maintenance pumps as well as reduced energy and resource consumption.

A complete vacuum solution covers all processes and steps involved in creating perfect vacuum conditions including consultation, products, accessories, application training programs and service. Our customers' requirements usually involve a high level of complexity. They not only include the precise vacuum requirements but also specific needs covering the entire system, the materials and products to be used and processed as well as process conditions. This is why we develop customized vacuum solutions hand in hand with our customers.

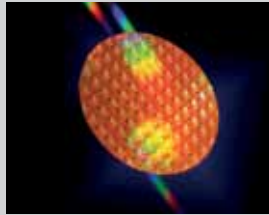

### Semiconductor

Sputter system

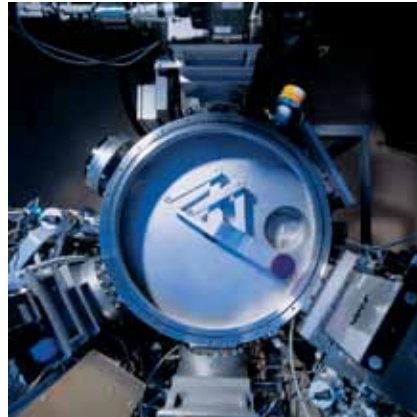

### Customer benefits

- Extra long service intervals
- Low energy consumption of the vacuum pumps
- On-site service for all product lines from a single source

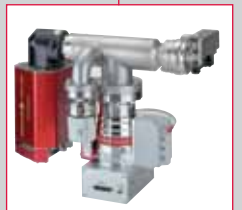



# Vacuum solutions from a single source

## Market segments and applications

### Industry

Leak detection



### Customer benefits

- Detection of smallest leakages
- High reproducibility
- High throughput and fast cycle times
- Maximum environmental benefit
- On-site service for all product lines from a single source



### Research & Development

Accelerator



### Customer benefits

- High reliability
- Special solution for accelerator applications
- Resistant to radioactive radiation
- Easy maintenance
- Highest quality and availability
- On-site service for all product lines from a single source



# Vacuum solutions from a single source

## Market segments and applications

### Coating

Glass coating



### Customer benefits

- Unmatched cost of ownership thanks to optimum pump design
- High availability due to robust design
- Largest product range in vacuum technology
- On-site service for all product lines from a single source



### Analytics

Mass spectrometry



### Customer benefits

- Specially coordinated component selection
- Common interfaces and easy control
- Synchronization of vacuum generation and -measuring
- On-site service for all product lines from a single source



# Vacuum solutions from a single source

## Market segments and applications

### eVacuum

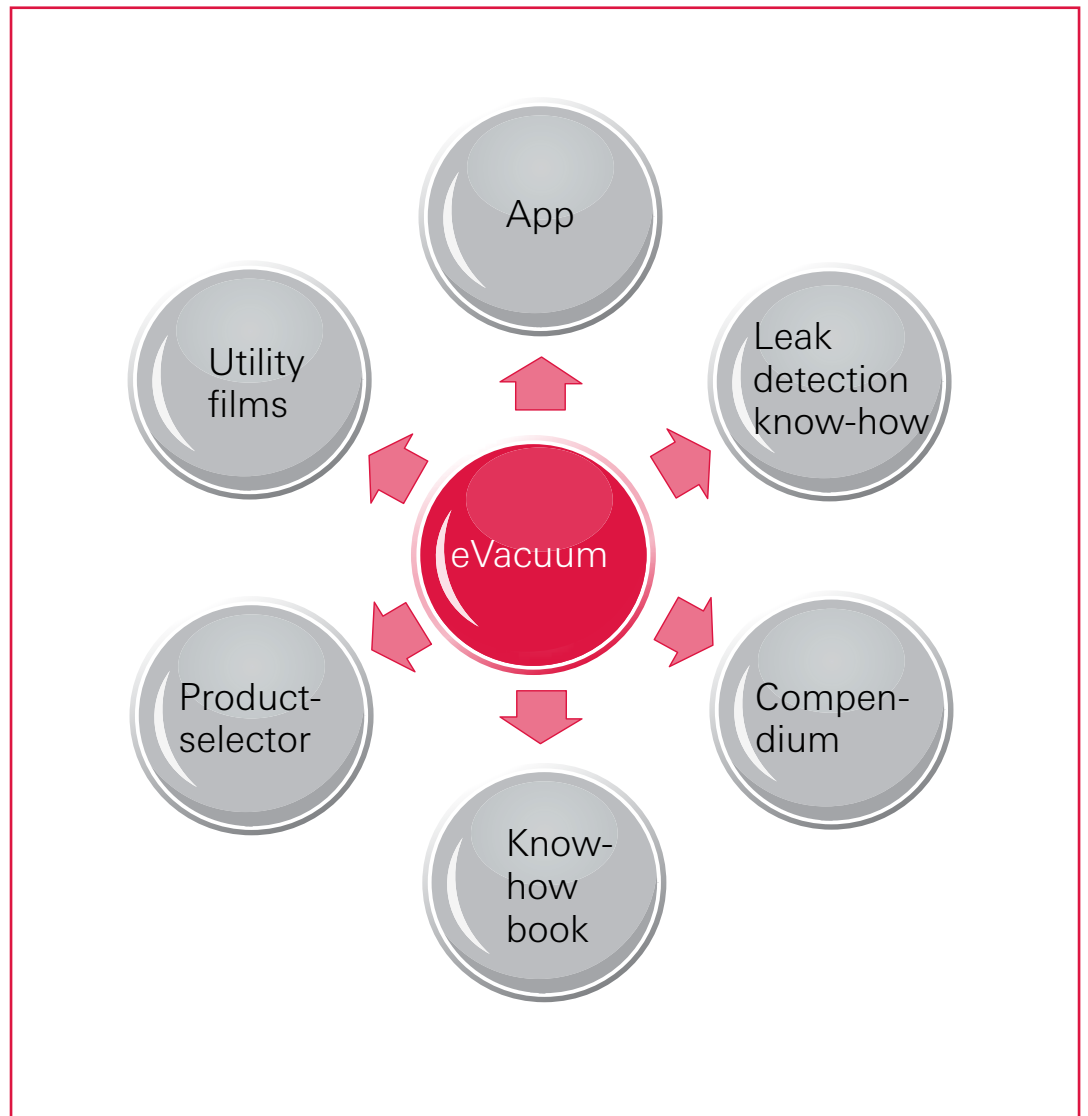

#### Customer benefits

- Central point of contact for questions concerning vacuum technology for customers and employees
- Simple, comprehensive and interactive knowledge



# Vacuum solutions from a single source

## Product overview



# Vacuum solutions from a single source

## Product overview

## Solutions

### Consulting competence

#### Applications



Know-how



Experience



Customer intimacy

#### Products

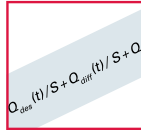

Dimensioning

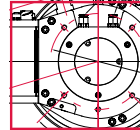

Engineering

#### eVacuum



Website



App

## Vacuum generation

### Service solutions

#### Worldwide quality



Representatives worldwide



Genuine parts



Training courses



Maintenance



...Austausch

### Turbopumps

#### Hybrid bearing



HiPace  
Pumping speed  
10 up to 2,000 l/s

#### Magnetically levitated



ATH M/HiPace M  
Pumping speed  
255 up to 2,800 l/s

#### Multi-stage



SplitFlow  
Pumping speed  
according to requirement

### Rotary vane pumps

#### Single-stage



UnoLine Plus  
Pumping speed  
250 up to 500 m<sup>3</sup>/h



HenaLine  
Pumping speed  
25 up to 1,000 m<sup>3</sup>/h



Pascal  
Pumping speed  
5.4 up to 15 m<sup>3</sup>/h



PentaLine  
Pumping speed  
22 up to 34 m<sup>3</sup>/h



DuoLine  
Pumping speed  
1.25 up to 250 m<sup>3</sup>/h



Pascal  
Pumping speed  
5.4 up to 60 m<sup>3</sup>/h

### Diaphragm pumps



MVP  
Pumping speed  
0.25 up to 9.6 m<sup>3</sup>/h

### Screw pumps



HeptaDry  
Pumping speed  
110 up to 525 m<sup>3</sup>/h

### Side channel pumps





OnTool Booster  
Pumping speed  
130 m<sup>3</sup>/h

# Vacuum solutions from a single source





## Product overview

## Vacuum generation

### Roots pumps

Air cooled	Gas cooled	Explosion-protected
		
<b>OktaLine</b> Pumping speed 250 up to 25,000 m <sup>3</sup> /h	<b>OktaLine G</b> Pumping speed 250 up to 12,000 m <sup>3</sup> /h	<b>OktaLine ATEX</b> Pumping speed 500 up to 4,000 m <sup>3</sup> /h





### Multi-stage Roots pumps

Light duty			Medium duty	Harsh duty
				
<b>ACP 15-40</b> Dry and compact	<b>A 100 L</b> Integrated load lock pump	<b>ACP 120/ACG 600</b> Dry, for industrial application	<b>A3P Serie</b> Energy efficient process pump	<b>A3H Serie</b> Harsh processes for semiconductor industry

### Turbo pumping stations



Compact	Standard	High performance
		
<b>HiCube Eco</b> Pumping speed 35 up to 67 l/s	<b>HiCube Classic</b> Pumping speed 35 up to 685 l/s	<b>HiCube Pro</b> Pumping speed 35 up to 685 l/s, short pump-down time

### Roots pumping stations

With single-stage backing pump	With two-stage backing pump	With dry backing pump	Compact pumping station	Dry pumping station
				
<b>CombiLine WU</b> Ultimate pressure up to 2 · 10 <sup>-3</sup> hPa	<b>CombiLine WD</b> Ultimate pressure up to 5 · 10 <sup>-4</sup> hPa	<b>CombiLine WH</b> Ultimate pressure up to 2 · 10 <sup>-3</sup> hPa	<b>LRS</b> Pumping speed 150 up to 1,000 m <sup>3</sup> /h	<b>DRS</b> Pumping speed 150 up to 1,000 m <sup>3</sup> /h





## Vacuum measurement

### Measurement equipment

Analog	Digital	Modular
		
<b>ActiveLine</b> Total pressure measurement	<b>DigiLine</b> Total pressure measurement	<b>ModulLine</b> Total pressure measurement for R&D

## Vacuum analysis

### Analysis equipment

Residual gas analysis	Gas analysis				
					
<b>PrismaPlus</b> Mass spectrometer Mass range 1-300 u	<b>HiQuad</b> Mass spectrometer Mass range 1-2048 u	<b>OmniStar</b> Compact benchtop analysis system	<b>HPA</b> High Pressure Analyzer Pressure range up to 50 hPa	<b>SPM</b> Sputter Process Monitor Pressure range up to 10 hPa	

# Vacuum solutions from a single source

## Product overview

## Leak detection

### Leak detectors

Portable	Compact	High performance	Workstation	Modular	Sniffing leak detection			
								
<b>MiniTest</b> Mobile, even for harsh environments	<b>ASM 310</b> Mobile service use	<b>ASM 340</b> High performance all-rounder	<b>ASM 380</b> Dry and mobile	<b>ASM 182 T</b> Robust industry standard	<b>ASM 192 T</b> Flexible console devices	<b>ASM 1002</b> Ergonomical test station	<b>ASI 30</b> Industrial leak detection systems	<b>ASM 102 S</b> Dry and portable

## System technology

### Plant construction

Contamination Management Solutions	Multi-stage vacuum process	Coating	Helium leak detection systems	Helium-Recoveryunits
				
<b>APA</b> Monitoring of contamination	<b>Vacu<sup>2</sup></b> For die casting processes	<b>Classic</b> Coating systems	<b>Complete systems</b>	<b>HRU</b> Ballon and wessel systems

## Vacuum components

### Chambers

### Components, valves, manipulators

Standard	Customized	Components	Hoses and flex connectors	Glass elements	Customized elements	Valves	Feedthroughs	Manipulators
								
<b>TrinosLine</b> Cubical, horizontal/vertical, modular	<b>TrinosLine</b> Customized for specific customer applications	ISO-KF, ISO-K, ISO-F, CF, COF	ISO-KF, ISO-K, CF	ISO-KF, ISO-K, ISO-F, CF	Customized for specific customer applications	Shut-off valves, gas dosing valves	Current/voltage, fluids, insulators, combinations	X-, Y-, Z-motion, rotation, tilting

**Vacuum solutions  
from a single source**

Pfeiffer Vacuum stands for innovative and custom vacuum solutions worldwide, technological perfection, competent advice and reliable service.

**Complete range  
of products**

From a single component to complex systems:  
We are the only supplier of vacuum technology  
that provides a complete product portfolio.

**Competence in  
theory and practice**

Benefit from our know-how and our portfolio of training  
opportunities! We support you with your plant layout  
and provide first-class on-site service worldwide.

**Are you looking for a  
perfect vacuum solution?  
Please contact us:**

**Pfeiffer Vacuum GmbH**  
Headquarters · Germany  
T +49 6441 802-0  
info@pfeiffer-vacuum.de